

LED High Bay

Benefits:

- Perfect solution for industrial applications
- Simple housing design, easy to install and replace
- Aluminum cover and body material
- Lifetime of up to 30,000 hrs.
- Overall cooling design, low light attenuation
- Up to 80% energy saving
- Lower maintenance cost
- UV & IR free light
- CRI>80
- IP44

Applications:

- Industrial area
- Warehouse
- Factory
- Store
- Supermarket
- Hallway
- Station
- Airport



General Characteristics:

Item	Watt	Luminous Flux (lm)	CRI (Ra)	CCT (K)	MOD (mm)	MOL (mm)	Voltage (V)	PF	Beam Angle
HB150-H350	150W	14000-15000	80	3000-6500K	410	H350	100-240V	0.9	60
HB200-H440	200W	19000-20000	80	3000-6500K	410	H440	100-240V	0.9	60
HB150-H315	150W	14000-15000	80	3000-6500K	466	H315	100-240V	0.9	100
HB200-H395	200W	19000-20000	80	3000-6500K	466	H395	100-240V	0.9	100

Cautions:

- Please read the contents on the box and label carefully before installation.
- Check if the specification e.g. voltage, current etc meet the requirements.
- Power must be cut off before installation, replacement and cleaning.
- Don't touch the luminaire while it is on or immediately after turning it off. Please wait 15 min. to cool down.

Remarks:

- Power consumption tolerance: +/- 10%.
- Luminous flux & cd tolerance: +/-10%.

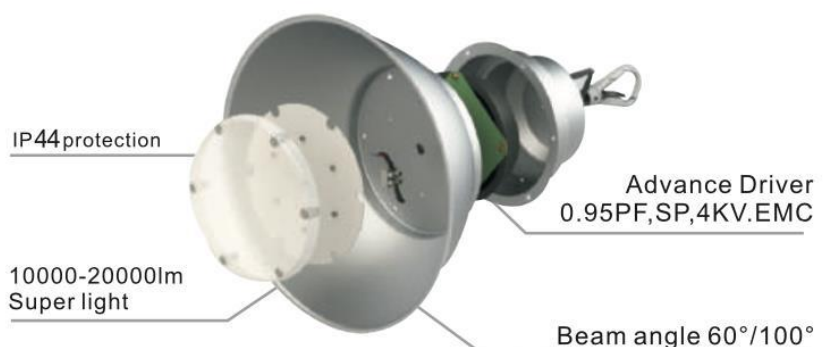

LED UFO High Bay

Benefits:

- Perfect solution for industrial applications
- Simple housing design, easy to install and replace
- Made of aluminum alloy
- Up to 80% energy saving
- Lower maintenance cost
- UV & IR free light
- CRI>80
- IP65
- High efficiency LED modules with 160lm/W OR 130lm/W
- Different beam angles available: 120°, 90° & 60°*
- Sosen/Moso/ZHIHE driver
- Dimmable version 1-10V available upon request
- IK07



Applications:

- Industrial area
- Warehouse
- Factory
- Store
- Supermarket
- Hallway
- Station
- Airport

General Characteristics:

Item	Watt	Luminous Flux (lm)	CRI (Ra)	CCT (K)	Voltage (V)	PF
HBU100	100W	13000-16000	80	4000-6000K	100-277V	0.95
HBU150	150W	19500-24000	80	4000-6000K	100-277V	0.95
HBU200	200W	26000-32000	80	4000-6000K	100-277V	0.95
HBU240	240W	31200-38400	80	4000-6000K	100-277V	0.95



Dimensions:

100W

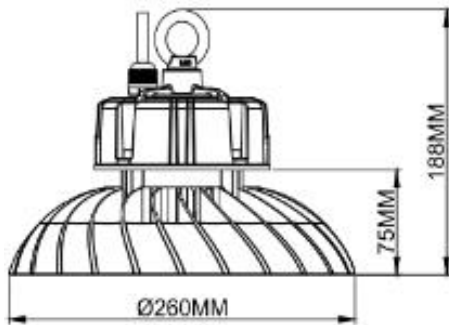

150W

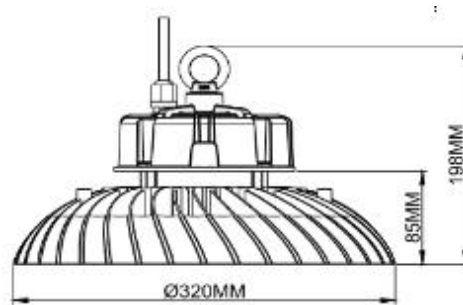

200W

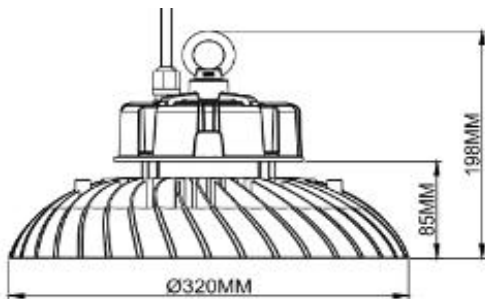

240W

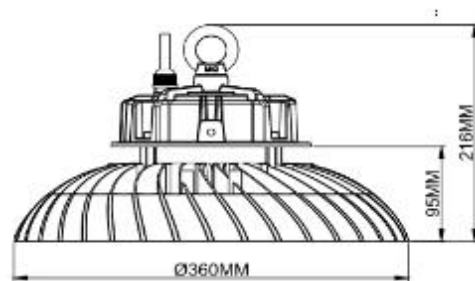

Cautions:

- Please read the contents on the box and label carefully before installation.
- Check if the specification e.g. voltage, current etc meet the requirements.
- Power must be cut off before installation, replacement and cleaning.
- Don't touch the luminaire while it is on or immediately after turning it off. Please wait 15 min. to cool down.

Remarks:

- Power consumption tolerance: +/- 10%.
- Luminous flux & cd tolerance: +/-10%

*60° Beam angle available for extra cost.

*Normal prices include cable with plug & 300mm. 1.5m cable also available upon request.

*Photos, descriptions and details of the product are subject to change without previous notice.

LED UFO High Bay

With adjustable beam angle, CCT & wattage



Benefits:

- With zoomable lens to adjust the beam angle from 60°/90°/105°
- With adjustable color temperature between 3000K, 4000K & 5000K
- Adjustable wattage or power consumption between 100W, 150W & 200W
- For interior & exterior applications, as well as for corrosive environment
- Easy to install and replace
- Made of die-casting housing & thermal conductive coating
- Up to 75% energy saving
- Lower maintenance cost, L70 50.000hrs
- UV & IR free light
- Samsung/Philips LEDs, up to 140lm/W
- Lifud/Meanwell driver
- Dimmable version available upon request
- Waterproof, dustproof & anticorrosive
- IP54 or IP65
- Motion sensor + PC reflector available upon request

Applications:

- Industrial area
- Warehouse
- Factory
- Store
- Supermarket
- Hallway
- Station
- Airport

General Characteristics:

Item	Watt	Luminous Flux (lm)	CRI (Ra)	CCT (K)	Voltage (V)	PF	LED
HBU100	100W	13000	80	3000-6000K	100-277V	0.9	Samsung
HBU150	150W	19500	80	3000-6000K	100-277V	0.9	Samsung
HBU200	200W	26000	80	3000-6000K	100-277V	0.9	Samsung



Distribution Diagram:

105°

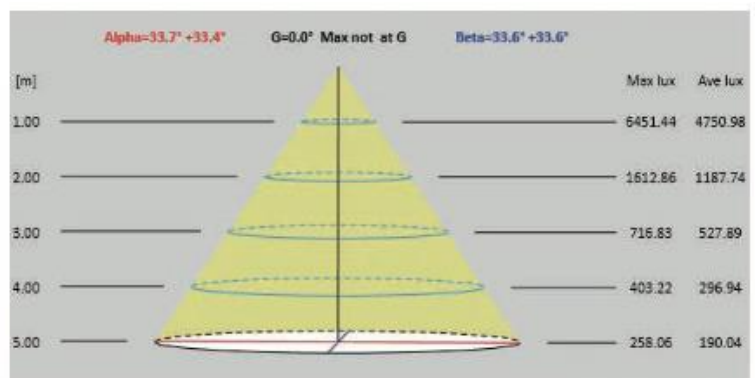
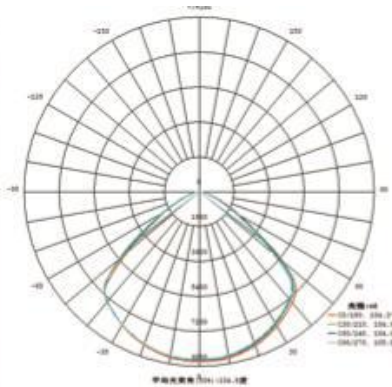
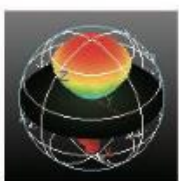

90°

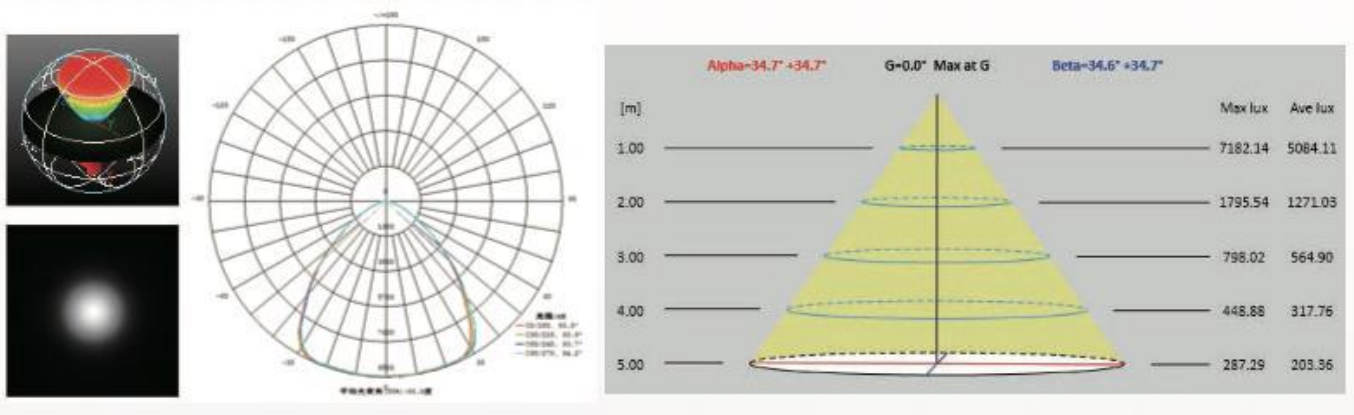

60°

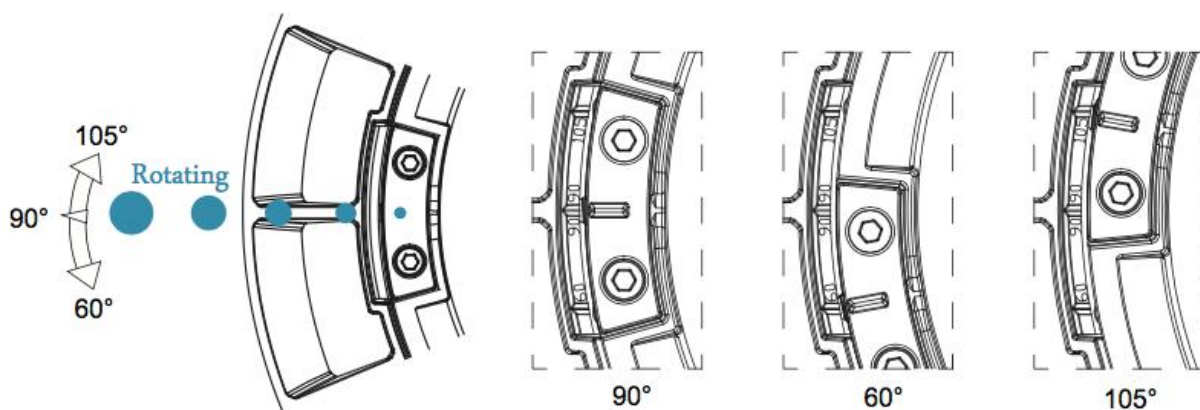
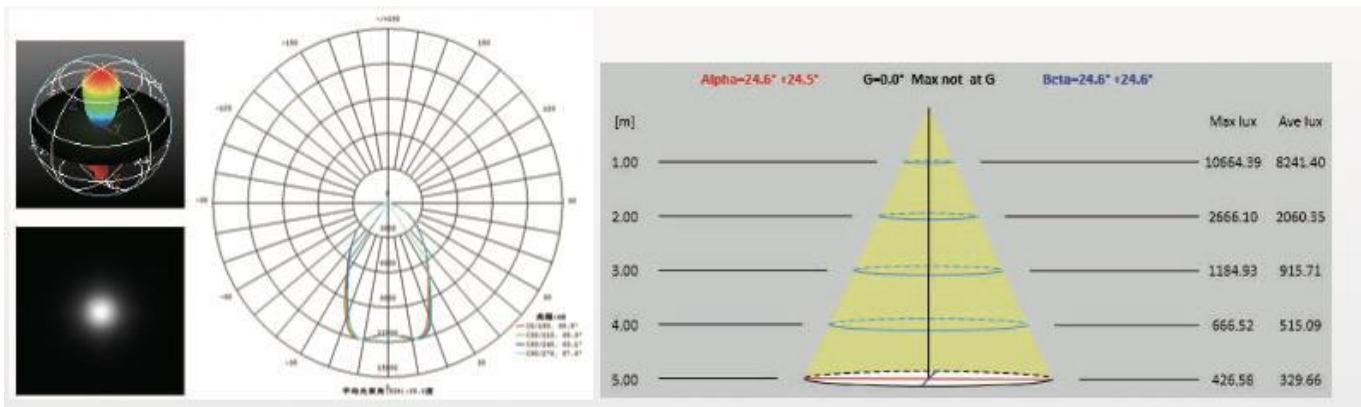

Cautions:

- Please read the contents on the box and label carefully before installation.
- Check if the specification e.g. voltage, current etc meet the requirements.
- Power must be cut off before installation, replacement and cleaning.
- Don't touch the luminaire while it is on or immediately after turning it off. Please wait 15 min. to cool down.

Remarks:

- Power consumption tolerance: +/- 10%.
- Luminous flux & cd tolerance: +/-10%.

*Photos, descriptions and details of the product are subject to change without previous notice.